

Modello/Model:	VMA 401
Tipo/Type:	Centrifugal Fan simple inlet
Uso/Use:	Clean air
Potenza installata/Installed power (Kw):	1,5Kw
Giri/1'/R.p.m.:	900
Frequenza/Frequency (Hz):	50
Tensione/Tension (V):	230/400

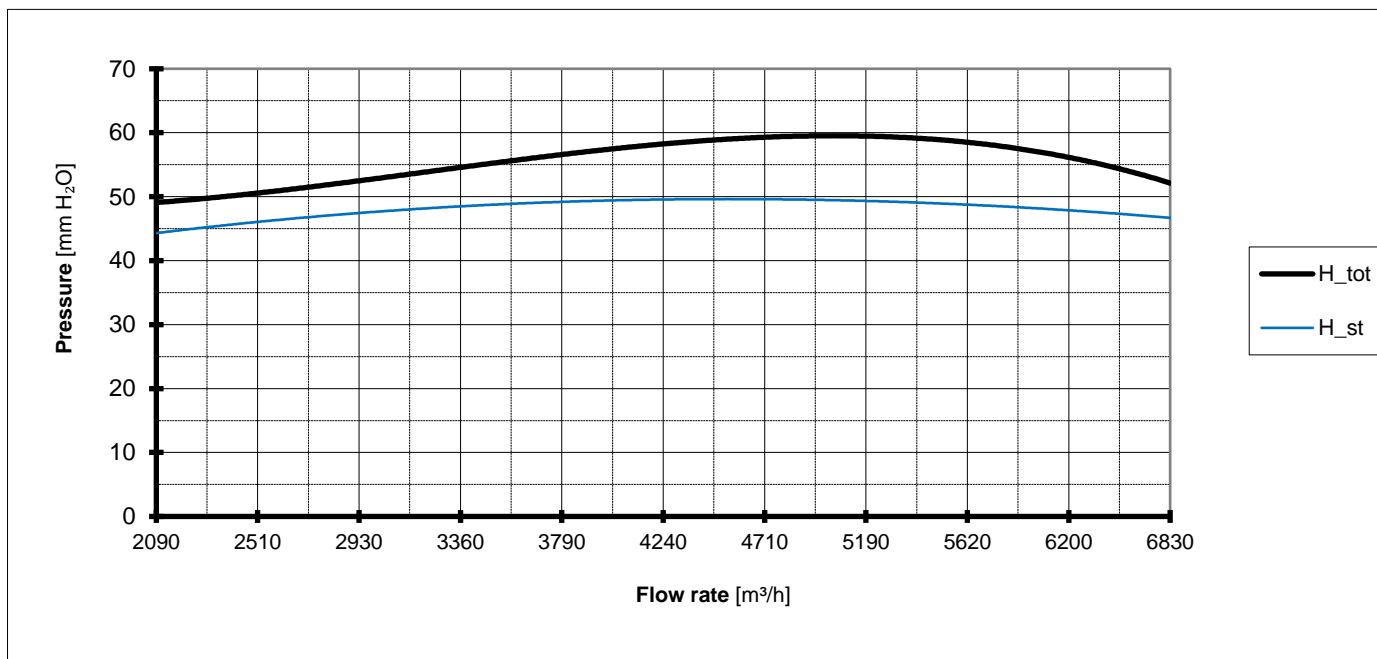

Livello di rumorosità a 1,5m/Noise level at 1,5mt. (dba):	57	
Motore tipo/Type motor:	B3 / B5	
Peso/Weight (Kg)	65	
Vernice/Painting:	Scroll:	RAL 5010
Std.: Polvere epossidica/Epoxidic dust	Impeller:	-
	Suction nozzle:	RAL 5010
Materiale costruttivo/Building material:	Fe 37	

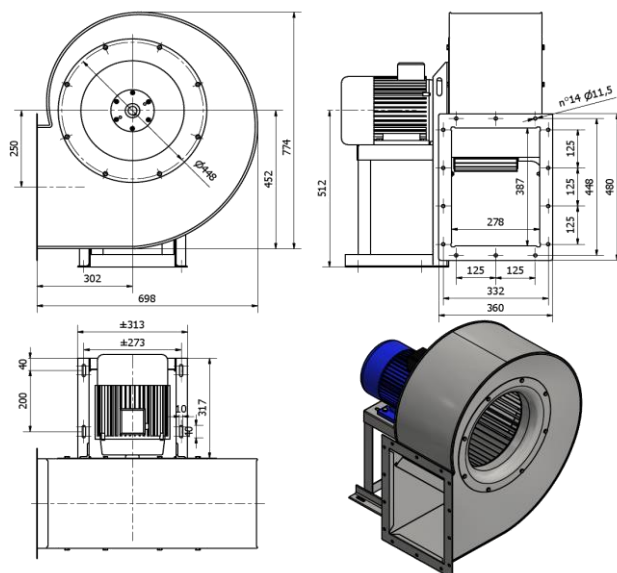

Ventilmotor S.r.l. a socio unico

Uffici e stabilimento: Via Piaggio, 74 - 20037 Paderno Dugnano (Mi) - **Sede Legale:** Via G. Pogliani, 34 - Paderno Dugnano (Mi)

Tel. +39 02.9101051 / +39 02.99041382 - Fax: +39 02.9103661 - info@ventilmotor.com - www.ventilmotor.com

Cap. Sociale € 10400,00 i.v. - REA 1519030 - N. Registro Imprese MI 53691 - Partita IVA 02632870966

ISO 9001
 Certificate N° 10-Q-10177-TIC



Modello/Model:	VMA 451
Tipo/Type:	Centrifugal Fan simple inlet
Uso/Use:	Clean air
Potenza installata/Installed power (Kw):	3Kw
Giri/1'/R.p.m.:	900
Frequenza/Frequency (Hz):	50
Tensione/Tension (V):	230/400

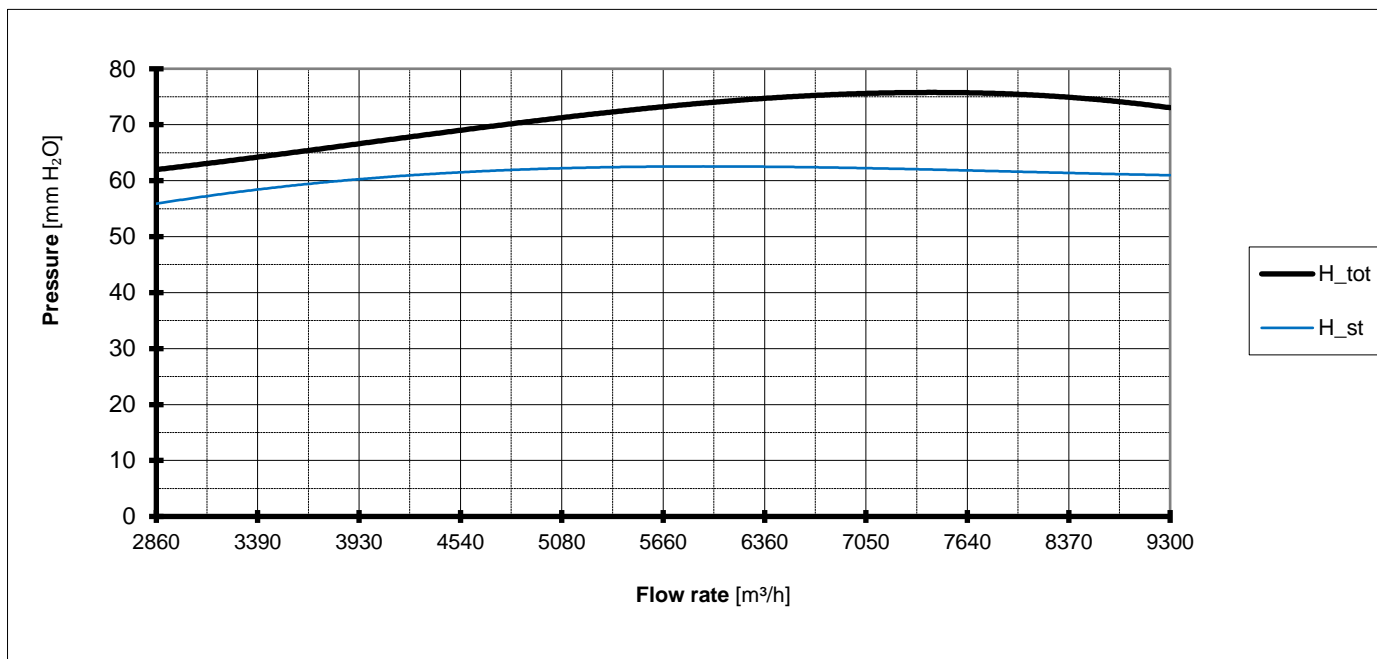

Livello di rumorosità a 1,5m/Noise level at 1,5mt. (dba):	61	
Motore tipo/Type motor:	B3 / B5	
Peso/Weight (Kg)	105	
Vernice/Painting:	Scroll:	RAL 5010
Std.: Polvere epossidica/Epoxidic dust	Impeller:	-
	Suction nozzle:	RAL 5010
Materiale costruttivo/Building material:	Fe 37	

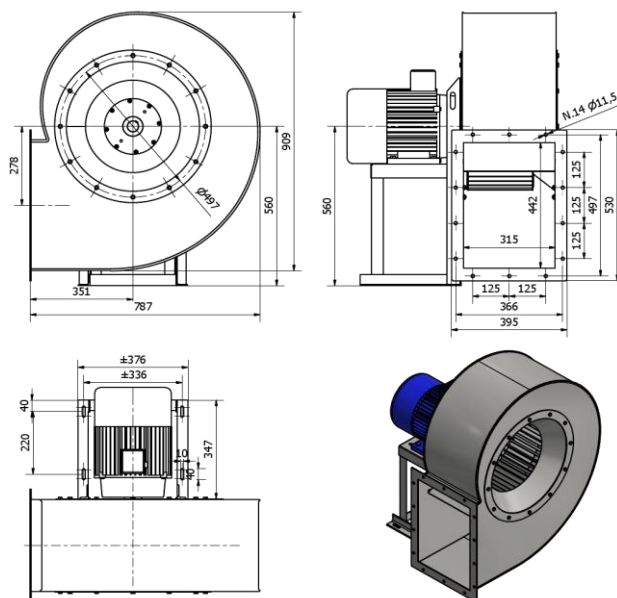

Ventilmotor S.r.l. a socio unico

Uffici e stabilimento: Via Piaggio, 74 - 20037 Paderno Dugnano (Mi) - **Sede Legale:** Via G. Pogliani, 34 - Paderno Dugnano (Mi)

Tel. +39 02.9101051 / +39 02.99041382 - Fax: +39 02.9103661 - info@ventilmotor.com - www.ventilmotor.com

Cap. Sociale € 10400,00 i.v. - REA 1519030 - N. Registro Imprese MI 53691 - Partita IVA 02632870966

ISO 9001
Certificate N° 10-Q-10177-TIC



Modello/Model:	VMA 501
Tipo/Type:	Centrifugal Fan simple inlet
Uso/Use:	Clean air
Potenza installata/Installed power (Kw):	4Kw
Giri/1'/R.p.m.:	900
Frequenza/Frequency (Hz):	50
Tensione/Tension (V):	230/400

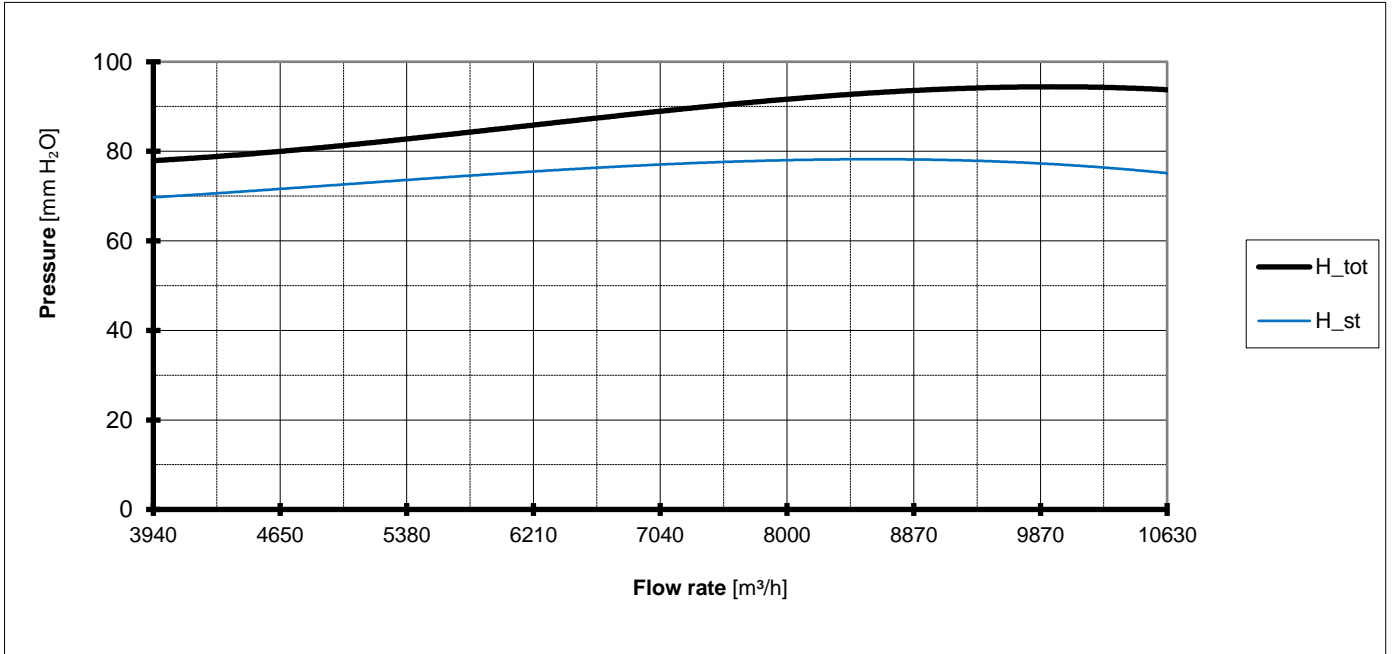

Livello di rumorosità a 1,5m/Noise level at 1,5mt. (dba):	61	
Motore tipo/Type motor:	B3 / B5	
Peso/Weight (Kg)	150	
Vernice/Painting:	Scroll:	RAL 5010
Std.: Polvere epossidica/Epoxidic dust	Impeller:	-
	Suction nozzle:	RAL 5010
Materiale costruttivo/Building material:	Fe 37	

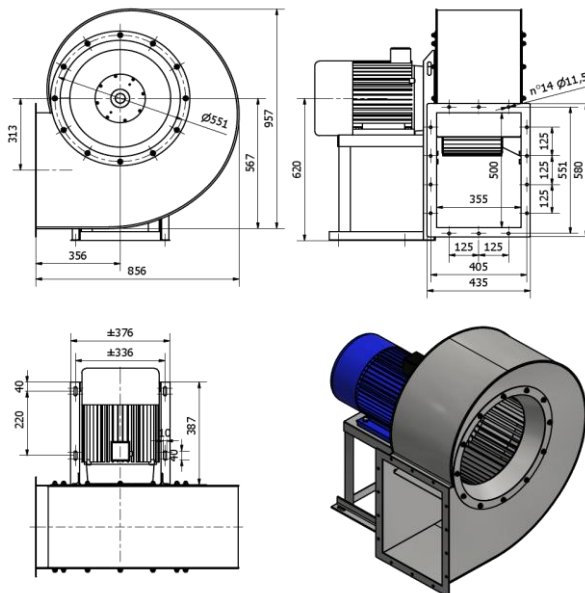

Ventilmotor S.r.l. a socio unico

Uffici e stabilimento: Via Piaggio, 74 - 20037 Paderno Dugnano (Mi) - **Sede Legale:** Via G. Pogliani, 34 - Paderno Dugnano (Mi)
Tel. +39 02.9101051 / +39 02.99041382 - Fax: +39 02.9103661 - info@ventilmotor.com - www.ventilmotor.com

Cap. Sociale € 10400,00 i.v. - REA 1519030 - N. Registro Imprese MI 53691 - Partita IVA 02632870966



Modello/Model:	VMA 561
Tipo/Type:	Centrifugal Fan simple inlet
Uso/Use:	Clean air
Potenza installata/Installed power (Kw):	7,5Kw
Giri/1'/R.p.m.:	900
Frequenza/Frequency (Hz):	50
Tensione/Tension (V):	230/400

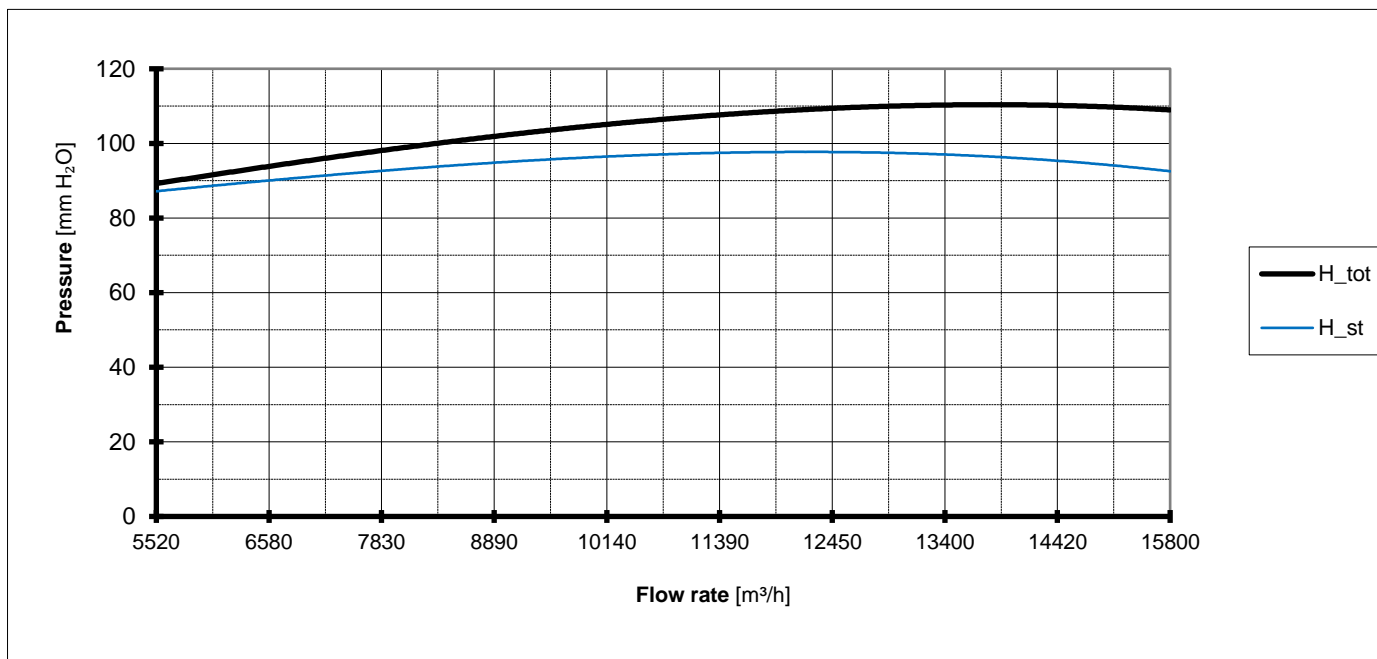

Livello di rumorosità a 1,5m/Noise level at 1,5mt. (dbA):	63
Motore tipo/Type motor:	B3 / B5
Peso/Weight (Kg)	220
Vernice/Painting:	Scroll: RAL 5010
Std.: Polvere epossidica/Epoxidic dust	Impeller: -
	Suction nozzle: RAL 5010
Materiale costruttivo/Building material:	Fe 37

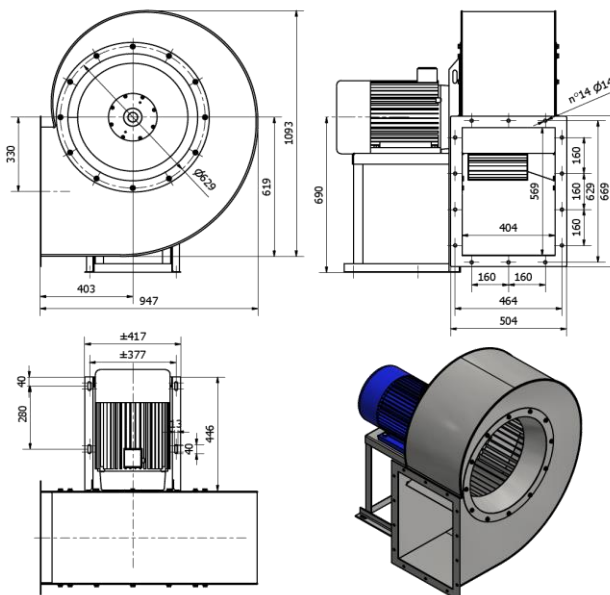

Ventilmotor S.r.l. a socio unico

Uffici e stabilimento: Via Piaggio, 74 - 20037 Paderno Dugnano (Mi) - **Sede Legale:** Via G. Pogliani, 34 - Paderno Dugnano (Mi)
Tel. +39 02.9101051 / +39 02.99041382 - Fax: +39 02.9103661 - info@ventilmotor.com - www.ventilmotor.com

Cap. Sociale € 10400,00 i.v. - REA 1519030 - N. Registro Imprese MI 53691 - Partita IVA 02632870966

